

UNIGEN CORP. WIRELESS MODULE PRODUCTS**PART NUMBER FAMILY:
JUNO-W WIRELESSUSB™ RADIO MODULES****UGWW2US SERIES
MEDIUM RANGE MODULES**

Issue Date: June 14, 2005

Revision: 1.10

Revision History

Rev. No.	History	Issue Date	Remarks
1.0	Final Release	13 June 2005	Final Release
1.1	Update	15 June 2005	Updated schematics

THIS DOCUMENT IS PROVIDED "AS IS" WITH NO WARRANTIES WHATSOEVER, INCLUDING ANY WARRANTY OF MERCHANTABILITY, NON-INFRINGEMENT, FITNESS FOR ANY PARTICULAR PURPOSE, OR ANY WARRANTY OTHERWISE ARISING OUT OF ANY PROPOSAL, SPECIFICATION OR SAMPLE.

Unigen Corporation disclaims all liability, including liability for infringement of any proprietary rights, relating to use of information in this document. No license, expressed or implied, by estoppel or otherwise, to any intellectual property rights is granted herein.

*Third-party brands, names, and trademarks are the property of their respective owners.

Copyright © Unigen Corporation, 2005

TABLE OF CONTENTS:

UNIGEN CORP. WIRELESS MODULE PRODUCTS	1
PART NUMBER FAMILY: JUNO-W WIRELESSUSB™ RADIO MODULES	1
UGWW2US SERIES SHORT RANGE MODULES	1
Revision History	1
REFERENCE DOCUMENTATION:	3
INTRODUCTION:	4
FEATURES:	5
DESCRIPTION:	5
FUNCTIONAL BLOCK DIAGRAMS:	5
ABSOLUTE MAXIMUM RATINGS:	6
RECOMMENDED OPERATING CONDITIONS:	6
DC ELECTRICAL CHARACTERISTICS:	7
Table 1 – Electrical Characteristics	7
RADIO PARAMETERS:	8
Table 3 – Radio Characteristics	8
PIN ASSIGNMENTS:	9
Table 4 – Pin Assignments	9
UGWW2US HEADER PIN-OUT:	9
PIN FUNCTIONS:	9
AGENCY CERTIFICATIONS (PRE-SCAN):	11
Table 5 – Regulatory Agency Certifications	11
Regulatory Compliance Statement:	11
MECHANICAL CHARACTERISTICS:	12
Table 6 – Mechanical Description	12
MECHANICAL DRAWINGS & PHYSICAL DIMENSIONS:	13
Figure 1 – JUNO-W Dimensions (Top View)	13
Figure 2 – JUNO-W Dimensions (Bottom View)	13
ORDERING INFORMATION:*	14
Typical Applications	14
CONTACT INFORMATION:	15

REFERENCE DOCUMENTATION:

The Unigen JUNO-W (UGWW2US) WirelessUSB™ module adaptation of the Cypress Semiconductor CYWM6935 LR 2.4GHz DSSS Radio SOC is represented in this document. The detail provided is information for using JUNO-W in a digital electronic device and is only a “companion” document to Cypress Semiconductors’ CYWUSB6935 documentation for the above noted part.

The CYWUSB6935 LR 2.4GHz DSSS Radio SOC 50-meter information and technical details (ex. register settings, timing, application interfaces, clocking and power management, etc.) may be obtained from the Cypress Semiconductor web site or contacting Cypress’s authorized sales representatives.

The following is a list of required documents and locations known at the time of publication that accompany this datasheet.

- The CYWUSB6935 LR 2.4GHz DSSS Radio SOC Datasheet – CYWUSB6935.pdf
<http://www.cypress.com/cfuploads/img/products/cywusb6934.pdf>

INTRODUCTION:

Unigen JUNO-W WirelessUSB™ 50 meter range module represents the convergence of emerging wireless connectivity solutions and the USB “Plug-N-Play” ease of operation. WirelessUSB, as created by Cypress Semiconductor, is a low-cost, 2.4GHz communication protocol designed for use in commercial, industrial, consumer, and computer product applications requiring highly reliable data connectivity.

JUNO-W module combine Cypress Semiconductor’s wireless and USB expertise with Unigen’s module design, manufacturing, and testing proficiency to create production ready, pre-certified modules that are easily integrated into existing, and new product designs.

JUNO-W module offer immediate, drop-in design solutions and use the native Operating System HID drivers to seamlessly enumerate and operate mouse, keyboard, and gaming devices, or other devices using the HID specification for communication with the host systems.

FEATURES:

- **CYWM6935 LR 2.4GHz DSSS Radio SOC**
- **Operates in the 2.4 to 2.483GHz, unlicensed frequency range (ISM – Industrial, Scientific and Medical)**
- **-95dBm receive sensitivity**
- **Up to 0dBm output power**
- **Range of 50 meters or more**
- **Data Rate of 62.5kbits/sec**
- **SPI interface**
(up to 2MHz data rate)
- **Operating Voltage Requirement**
2.7 – 3.6Vdc
- **Multiple connection interfaces available**
- **Small PCBA Design:**
UGWW2US
0.95" x 0.95" x 0.212" (23.75mm x 23.75mm x 5.3mm)(LxWxH)
- **Complete Radio Module**
Dual PCB Trace Antennas
- **Agency Pre-Certification FCC/EU/Industry Canada**
Module certified to FCC/EU compliance specifications limiting your agency compliance time and cost.
- **Agency Pre-Certification**
Tested to comply with Analog and Digital immunity standards from around the world
- **FCC Module Approval Grant**
Allows customers to adopt R8KUGWW2USHN33A FCC ID into their own products

DESCRIPTION:

JUNO-W WirelessUSB™ Modules are tightly integrated, low-cost, high-reliability 2.4GHz TX/RX communications modules for use with Human Interface Device (HID) class compliant products.

The JUNO-W 50-meter modules use the Cypress Semiconductor CYWUSB6935 LR 2.4GHz DSSS Radio SOC device.

JUNO-W modules are a complete radio solution requiring only integration into an existing, or new device.

JUNO-W modules are 100% tested for functional operation and are pre-screened for FCC Part 15 compliance. The modules are supplied with an integrated antenna. For applications where the integrated antenna is unsuitable, models are available that support using an external coaxial antenna. Unigen offers 2dBi gain antennae for customers requiring an external antenna.

JUNO-W modules are intended for use in computer and consumer product/device applications and use the OS native HID class drivers to enable compliant devices. In most applications, *no additional host drivers are required*. The modules are suitable for use in embedded and/or industrial applications as well.

The JUNO-W is less than 1"sq and is available with a keyed shrouded header mounting directly to the matching receptacle on the PCB. The modules are available bare-board for application off board within the device.

FUNCTIONAL BLOCK DIAGRAMS:

Simplified Block Diagram JUNO-W

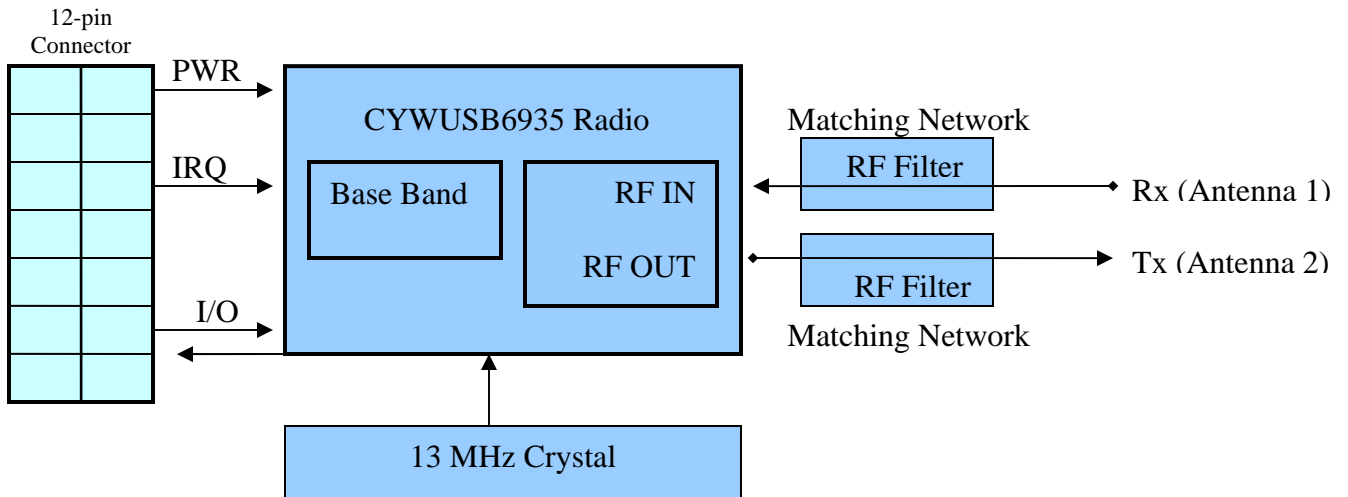

Simplified Block Diagram CYWUSB6935 Radio Chip

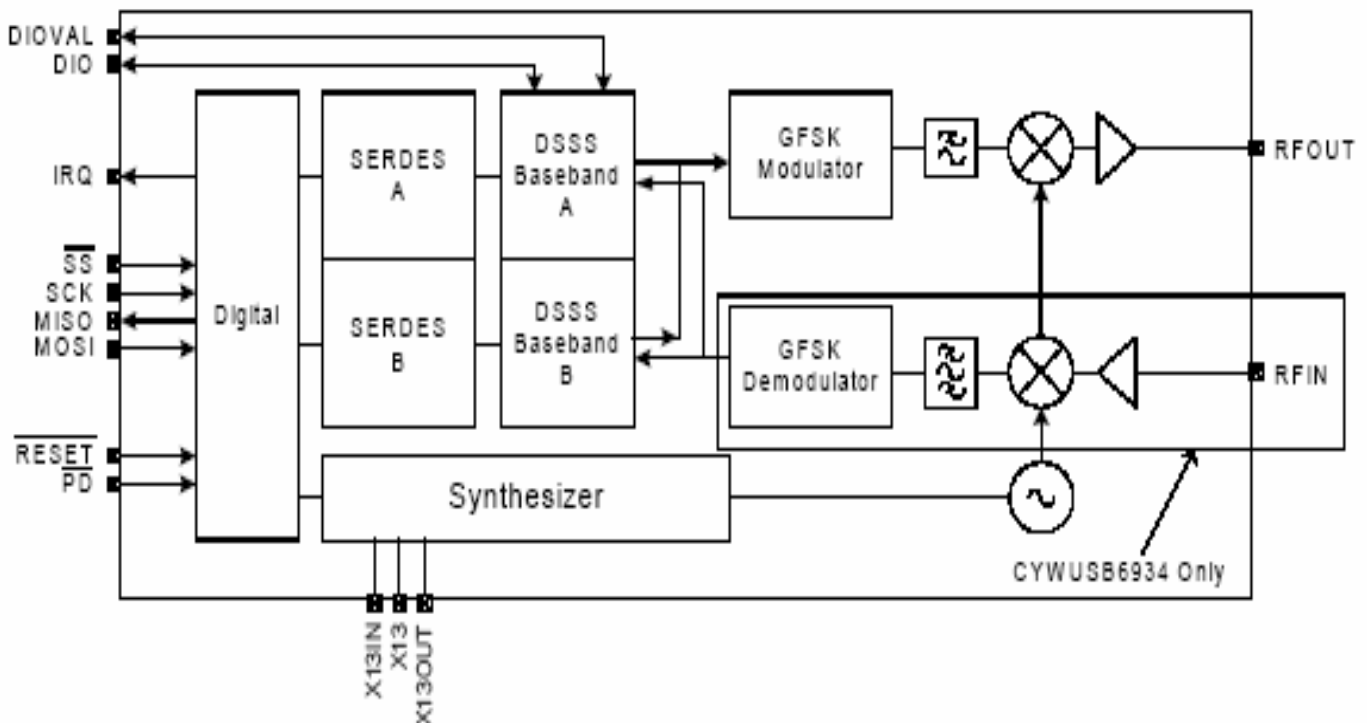

ABSOLUTE MAXIMUM RATINGS:

Symbol	Definition	Min.	Max.	Unit
VCC	Supply Voltage – Radio SOC	-0.3	3.9	VDC
TOC	Commercial Operating Temperature Range	-20	70	°C
Ts	Storage Temperature Range	-40	125	°C
VLI	VDC to Logic Inputs	-0.3	VCC + 0.3	VDC
V O/Hi-Z	VDC to Outputs in Hi-Z state	-0.3	VCC + 0.3	VDC
SDVD	Static Discharge Voltage Digital		>4000	VDC
SDVR	Static Discharge Voltage RF		>4000	VDC

These are stress ratings only. Exposure to stresses beyond these maximum ratings may cause permanent damage to, or affect the reliability of this module. Avoid using the module outside the recommended operating conditions defined below. This module is ESD sensitive and should be handled and/or used in accordance with proper ESD mitigation.

RECOMMENDED OPERATING CONDITIONS:

Symbol	Description	Value			
		Min.	Typ.*	Max.	Unit
VCC	Supply Voltage	2.7	3.0	3.6	VDC
Toc	Commercial Operating Temperature Range	-20	25	70	°C
GND	Ground Voltage		0		VDC

DC ELECTRICAL CHARACTERISTICS:

Symbol	Description	Condition(s)	Value			
			Min.	Typ.*	Max.	Unit
VCC	Supply Voltages		2.7	3.0	3.6	VDC
VOH1	Voltage Output High 1	At IOH = -100.0µA	VCC-0.1	VCC		VDC
VOH2	Voltage Output High 2	At IOH = -2.0 mA	2.4	3.0		VDC
VOL	Voltage Output Low	At IOL = 2.0 mA		0.0	0.4	VDC
VIH	Voltage Input High		2.0		VCC	VDC
VIL	Voltage Input Low		-0.3		0.8	VDC
IIL	Input Leakage Current	0 < VIN < VCC	-1	0.30	+1	µA
ISLEEP	Power-down current consumption	PD = Low		0.26	10	µA
TX AVG Icc1	Mean transmitter current consumption ¹	no handshake		6.0		mA
TX AVG Icc2	Mean transmitter current consumption ²	w/handshake		10.0		mA
RX Icc (Peak)	Current consumption during receive			60.0		mA
TX Icc (Peak)	Current consumption during transmit			71.4		mA
MTBF		Calculated			>87,600	Hours

Table 1 – Electrical Characteristics

* = Measured with 3.0Vcc at 25°C

¹= Mean Icc when transmitting a 5-byte packet (3 data bytes + 2 bytes of protocol) every 10ms using the Wireless USB LS 1-way protocol.

²= Mean Icc when transmitting a 5-byte packet (3 data bytes + 2 bytes of protocol) every 10ms using the Wireless USB LS 2-way protocol.

RADIO PARAMETERS:

Parameter Description	Condition	Min.	Typ.	Max	Unit
RF Frequency Range		2.400		2.483	GHz
Radio Receiver (T = 25°C, V _{CC} = 3.3V, f _{osc} = 13.000MHz, X13OUT off, 64 chips/bit, Threshold Low = 8, Threshold High = 56, BER ≤ 10 ⁻³)					
Sensitivity			-95		dBm
Maximum Received Signal		-20	-10		dBm
RSSI Value for PWR _{in} > -40dBm			28-31		
RSSI Value for PWR _{in} < -95dBm			0-10		
Interference Performance					
Co-channel Interference rejection Carrier-to-Interference (C/I)	C = -60 dBm		11		dB
Adjacent (1 MHz) channel selectivity C/I 1 MHz	C = -60 dBm		3		dB
Adjacent (2 MHz) channel selectivity C/I 2 MHz	C = -60 dBm		-30		dB
Adjacent (> 3 MHz) channel selectivity C/I > 3 MHz	C = -67 dBm		-40		dB
Image[22] Frequency Interference, C/I Image	C = -67 dBm		-20		dB
Adjacent (1 MHz) interference to in-band image frequency, C/I image ±1 MHz	C = -67 dBm		-25		dB
Out-of-band Blocking Interference Signal Frequency					
30MHz – 2399MHz except (FO/N & FO/N± 1MHz)	C = -67 dBm		-30		dBm
2498MHz – 12.75GHz, except (FO*N & FO*N±1MHz)	C = -67 dBm		-20		dBm
Intermodulation	C = -67 dBm, Δf = 5, 10MHz		-39		dBm
Spurious Emission					
30MHz – 1GHz				-57	dBm
1GHz – 12.75GHz (except 4.8GHz – 5.0GHz)				-47	dBm
4.8GHz – 5.0GHz				-37	dBm
Radio Transmitter (T = 25°C, V _{CC} = 3.3V, f _{osc} = 13.000MHz)					
Maximum RF Transmit Power	PA = 7		0		dBm
RF Power Control Range			30		dB
RF Power Range Control Step Size	Seven steps, monotonic		4.3		dB
Frequency Deviation	PN Code Pattern 10101010		270		kHz
Frequency Deviation	PN Code Pattern 11110000		320		kHz
Zero Crossing Error			±125		ns
Occupied Bandwidth	100-kHz resolution bandwidth, -6dBc	500			kHz
Initial Frequency Offset			±75		kHz
In-Band Spurious					
Second Channel Power (±2MHz)				-30	dBm
≥ Third Channel Power (≥3 MHz)				-40	dBm
Non-Harmonically Related Spurs					
30MHz – 12.75GHz				-57	dBm
Harmonic Spurs					
Second Harmonic				-20	dBm
Third Harmonic				-30	dBm
Fourth and Greater Harmonics				-47	dBm

Table 3 – Radio Characteristics

PIN ASSIGNMENTS:

Function	UGWM1US Pin #	I/O	Description
GND	1	-	Module Ground
Vcc	2	-	Module Input Power
IRQ	3	O	Interrupt Signal from Radio to the MCU
RSTn	4	I	Active low reset signal from MCU to Radio Module
MOSI	5	I	Master Out, slave in SPI signal from MCU to Radio Module
SSn	6	I	Active low slave select signal from MCU to Radio Module
SCK	7	I	SPI Clock from MCU to Radio Module
MISO	8	O	Master in, slave out SPI signal from Radio Module to MCU
GND	9	-	Module Ground
PDn	10	I	Active low power down signal from MCU to Radio Module
N/C	11	-	No Connect – leave open
N/C	12	-	No Connect – leave open

Table 4 – Pin Assignments

UGWW2US HEADER PIN-OUT:

12-pin 2mm Header

GND	1	2	Vcc
IRQ	3	4	RSTn
MOSI	5	6	SSn
SCK	7	8	MISO
GND	9	10	PDn
N/C	11	12	N/C

PIN FUNCTIONS:

MOSI:	SPI Input from MCU Receives commands/data from the device microcontroller.
MISO:	SPI Output to MCU Transmits requests/data to the device microcontroller.
SSn:	SPI Slave Select Enable Input SPI enable
IRQ:	Interrupt Request The Interrupt Request Pin Select bits are used to determine the drive method of the IRQ pin
GND:	Module Ground
RSTn:	Module Reset Active LOW reset switch
SCK:	SPI Input Clock
PDn:	Power Down Driving signal LOW will put the module in SUSPEND MODE (X13OUT = 0 when PDn is LOW)
Vcc:	Module Input Power Vcc range 2.7 to 3.6Vdc

AGENCY CERTIFICATIONS (PRE-SCAN):

Agency	Test Performed	Type	Limit	Result	Margin
EU	Radiated Spurious Emissions	30-12.75MHz Transmit Mode	EN 300 328	PASS	-4.6dB @ 4804MHz
		30-12.75MHz Transmit Mode	EN 300 328	PASS	-4.9 @ 177.01MHz
FCC 15.247	Radiated Emissions	30 25,000 Spurious Emissions	FCC Part 15.209/15.247 (c)	PASS	Results on File
		6dB Bandwidth	15.247(a)	PASS	960kHz
		99% Bandwidth	IC RSS-210	PASS	1.175MHz
		Output Power	15.247(b)	PASS	7.2dBm
		Power Spectral Density (PSD)	15.247(d)	PASS	3.06dBm
		Bandedge	FCC Part 15.209 /15.247(c)	PASS	Results on File
		Out of band	15.247(c)	PASS	Results on File
EU	Radio Performance Test	Output Power, Power spectral density at normal conditions	EN 300 328-1	PASS	Results on File
		Frequency Range at normal conditions	EN 300 328-1	PASS	Results on File
		Output Power over extreme conditions	EN 300 328-1	TBT	
		Frequency Range over extreme conditions	EN 300 328-1	TBT	
		Conducted spurious emissions, 30MHz - 12750MHz, transmit mode	EN 300 328-1	PASS	Results on File
		Conducted spurious emissions, 30MHz - 12750MHz, receive/stand-by mode	EN 300 328-1	PASS	Results on File
	Radiated Spurious Emissions	30 - 12,750 MHz -Spurious Emissions Transmit Mode	EN 300 328 V1.2.1	PASS	Results on File
		30 - 12,750 MHz -Spurious Emissions Receive Mode	EN 300 328 V1.2.1	PASS	Results on File

Table 5 – Regulatory Agency Certifications

Regulatory Compliance Statement:

The module has been pre-scanned against the relevant requirements of standards: EN 300 328, EN 301 489-17, FCC part 15 and Industry Canada RSS-210. The module is certified by the regulatory authorities in the USA and Canada and complies with the applicable essential requirements of the Radio & Telecommunication Terminal Equipment (R&TTE) directive in the EU. The module can thus be incorporated into products sold worldwide with little or no additional testing of the module itself. ***The end product must meet the appropriate technical requirements that apply to that product type but re-certification of the radio module is not required in the USA and Canada.***

In the EU, the integrator is responsible for evaluating their product type per the essential performance requirements of the R&TTE directive (except those associated with the module), declaring compliance and then notifying the member states prior to marketing the product (because the module uses a frequency band that is not harmonized in the EU). It is the responsibility of the module integrator to obtain the necessary approvals to sell products incorporating this module in other countries outside of North America and the EU. The report of measurements performed on the module in compliance with the FCC rules and EN standards can be used in these submittals (as the requirements in many other markets around the world are based in part or in whole on the standards prevalent in North America and the EU).

MECHANICAL CHARACTERISTICS:

Item	Description	Specification
1	PCB Material	FR-4
2	PCB Layers	2
3	Connector Type	Straight thru-hole or header; Please see Table 4 for pin assignments
4	PCB Number	1
5	Flammability Rating	UL94 V-0
6	UGWW2US Dimensions	0.950" x 0.950" x 0.375" (23.75mm x 23.75mm x 5.3mm) ±.01%
8	Antenna	Antenna Diversity Double Wiggle Trace
9	User Serviceable Parts	None

Table 6 – Mechanical Description

MECHANICAL DRAWINGS & PHYSICAL DIMENSIONS:

Figure 1 – JUNO-W Dimensions (Top View)

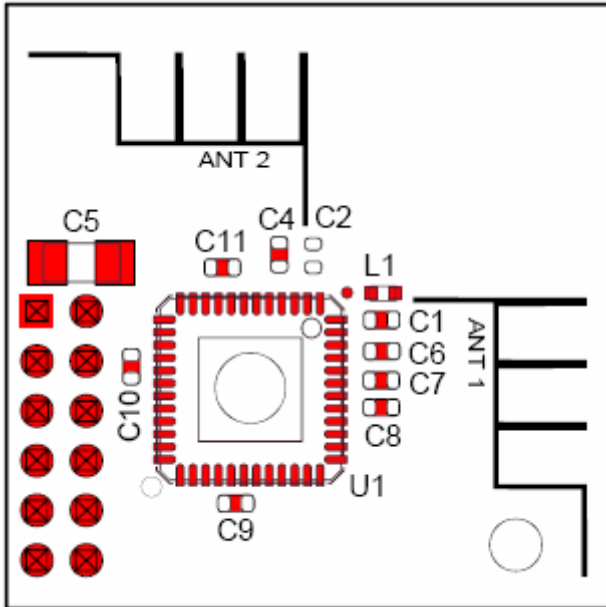
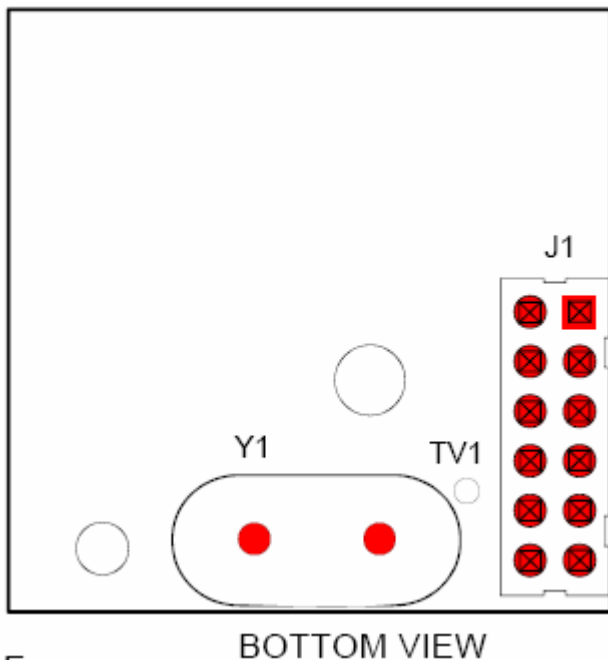

Figure 2 – JUNO-W Dimensions (Bottom View)





WirelessUSB™ - UGWW2US

Solutions for a Real Time World

Data Sheet

ORDERING INFORMATION: *

Typical Applications

UNIGEN PRODUCT GROUP – WIRELESS -	FORM FACTOR	WIRELESSUSB TECH	CONNECTION	CONNECTOR TYPE	VOLTAGE	ANTENNA
UGW	W	2US (50M)	HN	MIRRORED 2X6 HEADER	33=3.3VDC	A=INTEG. CHIP

*Module based on the Cypress Semiconductor CYWUSB6935 WirelessUSB™ LR 2.4GHz DSSS Radio SoC device.

Contact your Unigen Sales Representative for additional information or visit the Nexus™ Wireless Products section of our web site (www.unigen.com).



Solutions for a Real Time World

WirelessUSB™ - UGWW2US

Data Sheet

CONTACT INFORMATION:

CORPORATE HEADQUARTERS

Unigen Corporation
45388 Warm Springs Boulevard
Fremont, CA 94539

Telephone:	1.510.688.2088
Fax:	1.510.661.2788
Email:	Support@unigen.com
Web:	www.unigen.com
Customer Comment:	1.800.826.0808